

CrossPATH* CSU Functionality

Application Note **Overview**

CrossPATH® from Kentrox sets new standards for efficiency and innovation. Its economical platform delivers high-capacity base station connectivity for the growth of existing networks and seamless migration to next-generation wireless services (see Figure 1). The CrossPATH also leverages a cutting-edge Quality of Service (QoS) router utilizing Web browser GUI technology for unparalleled management flexibility and ease of use.

This application note addresses the CSU functionality in CrossPATH, including:

- Lightning protection
- Signal regeneration
- Signal level monitoring
- T1 performance monitoring
- AMI to B8Zs conversion
- Clear channel or structured T1 support
- DS0 level cross connection
- Hardened for harsh environments

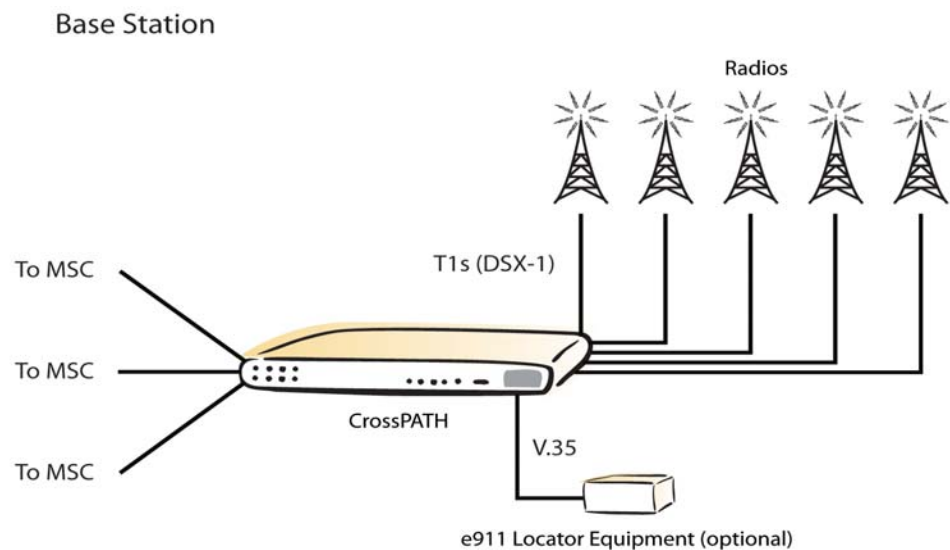

Figure 1: One CrossPATH replaces multiple CSUs and reduces T1 backhaul circuits.

Lightning protection

CrossPATH provides proven cell site lightning protection meets the Telcordia GR-1089 standard which exceeds standard FCC requirements of CSUs. In handling line surges caused by lightning strikes, the CrossPATH has integrated circuitry that shunts the excess power to ground. The circuitry is not fused, so it enables the CrossPATH to self-recover from nearly any lightning-induced power surges. This provides two key benefits to the cell site operator.

* CrossPATH refers to CrossPATH 3G and 4.

First, CrossPATH provides a high level of protection for expensive base station equipment from surges coming through the T1 line. Relying on the CSU functionality built into many base station T1 cards could result in T1 line card failure due to lightning strikes. Installing a CrossPATH to provide surge protection would save the cost of the card replacement along with the labor required to perform the swap out. In addition, costly cell site down time would be eliminated.

Second, when lightning surges do occur, the self recovering feature built into CrossPATH eliminates the need for a technician to be dispatched to replace a blown fuse. This would result in a reduced number of truck rolls to keep the cell site operational, thereby lowering support costs and increasing cell site up time.

Signal regeneration

The CrossPATH receives the incoming T1 signal and extracts the binary data. The receive sensitivity of a CrossPATH is -30 db which exceeds the FCC requirement for CSUs. This permits even a weak signal to be read and properly regenerated. This allows CrossPATH to compensate for poor signal quality, which is beyond the capability of most base station line cards. In addition, the CrossPATH has settings to control the strength of the regenerated signal which can compensate for long cable runs. This capability provides the cell site operator with an improved T1 signal delivered to the base station, enhancing call quality and eliminating cell site downtime due to T1 degradation.

Signal level monitoring

Poor T1 signal quality is a leading cause of technician troubleshooting and truck rolls. CrossPATH monitors the T1 signals from the base station and the Telco and displays the measurement in both db and voltage formats. These values are stored in the unit for seven days and are easily read by the technician through the CrossPATH's remote management capability. By tracking the signal levels, a degrading T1 can be identified and corrected before it becomes an outage.

Signal level monitoring can prevent cell site outages with alarm notification of degrading T1 signal levels. When T1 levels fall below a user defined level, an SNMP trap can be sent to the Network Operations Center to notify technicians of T1 degradation. This enables operators to proactively resolve the problem before cell site outages occur.

T1 performance monitoring

In addition to monitoring the signal level, the CrossPATH records all bit errors on a T1 line. By tracking bit level errors, the Telco can be notified of problem areas so corrective action can be taken before an outage occurs. Loopback functionality is built into CrossPATH. Tests can be run on the lines to identify the source of the errors. In addition, a QRS BERT test can be run from the CrossPATH which minimizes the need for locating costly test equipment and inserting it into the line. In conjunction with the remote management functionality of the CrossPATH, the BERT test can be run remotely from a technician's laptop without having to go to the site. This is one more way in which the CrossPATH can allow an operator to reduce truck rolls and enhance cell site uptime.

AMI or D4 conversions

If you are currently using AMI or D4, you may need to convert to B8ZS or ESF, respectively. The CrossPATH includes built-in functionality to easily convert these from one format to another. You don't need to worry if the only T1 signal in a given area or if older cell site equipment only supports AMI/D4 - CrossPATH can convert it.

Clear channel or structured T1 support

Some cell site applications require the presence of either a clear channel T1 or a structured T1 interface. Support for both these formats, along with full support for fractional T1s, is inherent in the CrossPATH. This provides the operator with a great deal of flexibility in choosing cell site applications without regard to the radio access network equipment.

DS0 level cross connects

CrossPATH provides the ability to map any incoming DS0 to any other outbound DS0. This grooming capability allows cell site operators to fill up T1s that may otherwise be partially empty and potentially reduce the need for excess T1 capacity.

Hardened for harsh environments

The CrossPATH is designed to operate in temperatures ranging from -20 C to 65 C (-4 F to 149 F) along with non-condensing humidity from 5% to 95%. CrossPATH will perform well in a cell site whether it is located in sultry South Florida or arid Arizona. The power supply can be either 24 or 48 volts DC, and consumption is only 20 watts.

Summary

Kentrox is an industry leader in quality network access products and providing solutions that are easy to install and manage, meeting the growing needs for both wireline and wireless access products. Kentrox continues to meet and exceed the networking requirements by providing innovative solutions for a very attractive price. Kentrox is the leader in hardened CSUs for cell sites with nearly one million T1 CSUs shipped.

The integrated CSU functionality in the Kentrox CrossPATH provides built-in fault protection and diagnostics to improve cell site uptime while lowering support costs. Combining this with an easy to use GUI and management flexibility, CrossPATH is the right solution for any organization.

04-03-008-1 4/06 Copyright © 2006 by Kentrox, LLC. All Rights Reserved. Kentrox and CrossPATH are registered trademarks of Kentrox. All other products are trademarks of their respective owners. Information published here is current as of the date of publication. You may verify information by contacting our headquarters in Hillsboro, Oregon. Kentrox is an Equal Employment Opportunity/Affirmative Action employer.

Kentrox
20010 NW Tanasbourne Drive
Hillsboro, OR 97124
Phone 503-643-1681
Toll Free 800-733-5511
www.kentrox.com